

# HSR&PRP&PTP

## Test Plan

This document could contain technical inaccuracies or typographical errors. Flexibilis Oy may make changes in the product described in this document at any time.

Please, email comments about this document to [support@flexibilis.com](mailto:support@flexibilis.com).

© Copyright Flexibilis Oy 2014. All rights reserved.

Trademarks

All trademarks are the property of their respective owners.

## Contents

---

<b>1 About This Document .....</b>	<b>6</b>
1.1 Vertigo.....	6
<b>2 Standards .....</b>	<b>7</b>
2.1 HSR.....	7
2.2 PRP.....	9
2.3 PTP .....	10
<b>3 Test Network .....</b>	<b>12</b>
3.1 General .....	12
3.2 What to Test.....	15
3.2.1 HSR/PRP Switch IP Provider .....	15
3.2.2 Application Provider .....	15
3.2.3 Device Manufacturer .....	16
3.3 Test Equipment.....	17
<b>4 Test Cases.....</b>	<b>18</b>
4.1 RFC 2544 Traffic Tests.....	18
4.1.1 Throughput Test.....	18
4.1.1.1 Acceptance Criteria.....	19
4.1.2 Latency Test.....	19
4.1.2.1 Acceptance Criteria.....	20
4.1.3 Frame Loss Test .....	20
4.1.3.1 Acceptance Criteria.....	21
4.2 Stream Sweep Tests.....	22
4.2.1 Link Breaking Sequence .....	24
4.2.2 Acceptance Criteria .....	24
<b>5 Abbreviations.....</b>	<b>26</b>
<b>6 References .....</b>	<b>27</b>

## Figures

---

Figure 1. HSR Ring Example with Unicast Message .....	7
Figure 2. HSR Ring Example with Multicast Message .....	8
Figure 3. HSR Tagged Frame .....	8
Figure 4. PRP Network.....	9
Figure 5. PRP Frame.....	10
Figure 6. PTP Architecture .....	10
Figure 7. PTP Power Profile in HSR.....	11
Figure 8. Test Network .....	14
Figure 9. Test Automation .....	14
Figure 10. Transmit Rate Ramp up .....	24

## Tables

---

Table 1. Test Equipment Needed.....	17
Table 2. Optional Additional Test Equipment.....	17
Table 3. Throughput Test Interface Types .....	18
Table 4. Throughput Test Frame Sizes.....	18
Table 5. Throughput Test Acceptance Criteria for FRS .....	19
Table 6. Latency Test Interface Types .....	19

Table 7. Latency Test Frame Sizes .....	20
Table 8. Latency Test Acceptance Criteria for FRS .....	20
Table 9. Frame Loss Test Interface Types.....	21
Table 10. Frame Loss Test Frame Sizes .....	21
Table 11. Frame Loss Test Acceptance Criteria for FRS.....	22
Table 12. Stream Sweep Test Interface Types .....	22
Table 13. Stream Sweep Test Frame Sizes.....	23

## Revision History

---

Rev	Date	Comments
0.1	27.10.2011	First version.
0.2	9.3.2012	Added support for PRP
0.3	9.3.2012	Updates from review
1.0	12.3.2012	Approved
1.1	15.3.2013	Updated
2.0	14.2.2014	Rewritten
2.1	18.2.2014	Moved to new document template

## 1 About This Document

This document presents a test plan for High-availability Seamless Redundancy (HSR) and Parallel Redundancy (PRP) networks running Precision Time Protocol (PTP). The test plan presents a network using real physical devices implementing HSR, PRP and PTP. At Flexibilis this network is used to test functionality of Flexibilis reference designs for Altera development boards (Cyclone IV and Cyclone V GX, GT and SoC boards). The devices under test employ the following Flexibilis IP blocks and products:

- FRS
- AFEC
- FRTC
- HSR/PRP Supervision
- PTP Protocol Stack

The test network and the test cases are designed so that with small changes almost any devices implementing HSR and/or PRP can be tested with them. At Flexibilis the tests are run automatically, controlled by CI (Continuous Integration) server, but the tests can also be run manually.

### 1.1 Vertigo

This document presents the tests and the test network that is used for system level testing at Flexibilis. The main test method for testing Flexibilis IP blocks at block level is still Flexibilis' own hardware accelerated simulation environment Vertigo. Vertigo is not presented in this document.

## 2 Standards

This test plan refers to three protocol standards:

1. IEEE Standard for a Precision Clock Synchronization Protocol for Networked Measurement and Control Systems, IEEE Std 1588™-2008 [1]
2. High-availability Seamless Redundancy (HSR) and Parallel Redundancy Protocol, IEC 62439-3:2011 [2]
3. IEEE Standard Profile for Use of IEEE 1588™ Precision Time Protocol in Power System Applications, IEEE Std 37.238™-2011 [3]

The first standard in the list defines Precision Time Protocol (PTP) that is used for clock synchronization over packet networks. The second one defines methods called HSR (High-Availability Seamless Redundancy) and PRP (Parallel Redundancy Protocol) that provide redundancy for Ethernet networks. The third one defines how to use PTP in power system applications.

The following chapters introduce the referred protocols.

### 2.1 HSR

HSR [2] is a method to provide redundancy in Ethernet networks. The concept introduces network ring(s) where every source and destination pair is connected via two routes. In case of a fault, the ring breaks, but still provides connection between source and destination(s) via second path, as shown in Figure 1 and Figure 2. The standard has been developed for demanding and critical applications such as substation automation.

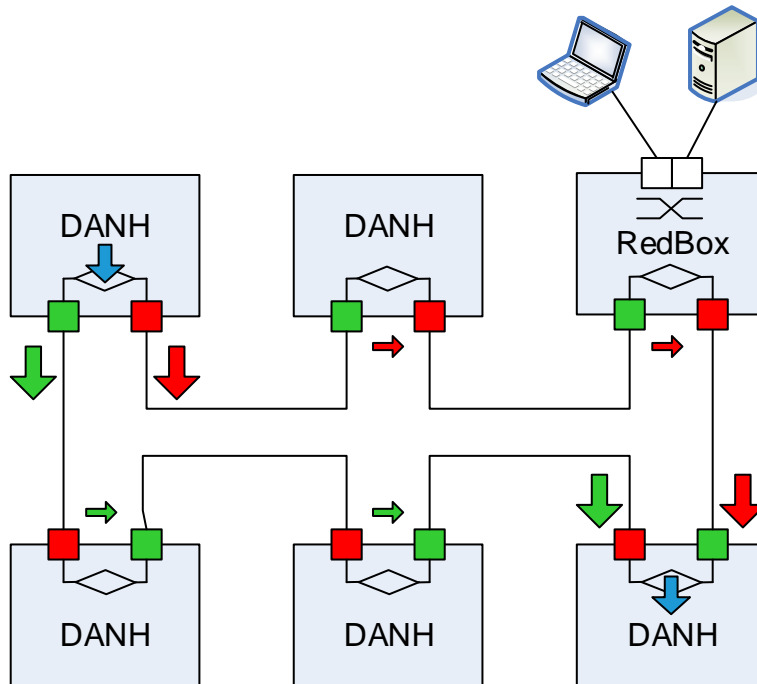

**Figure 1. HSR Ring Example with Unicast Message**

In Figure 1 the blue arrow shows normal Ethernet frame transfer direction. Green and Red arrows show HSR tagged Ethernet frame transfer in the ring. For unicast messages (Figure 1) Ethernet frame leaves source node as duplicated: a HSR tagged frame is sent to both directions in the HSR ring. The destination node receives both HSR tagged frames, forwards the first frame to the end-node and discards the duplicate frame that arrives later. In this unicast case the destination node does not forward either one of the HSR tagged unicast frames to the ring, it removes the frames from the ring.

For multicast frames (Figure 2) the operation is almost the same, but the destination node forwards both HSR tagged frames to the ring and it is the source node that removes the both copies from the ring.

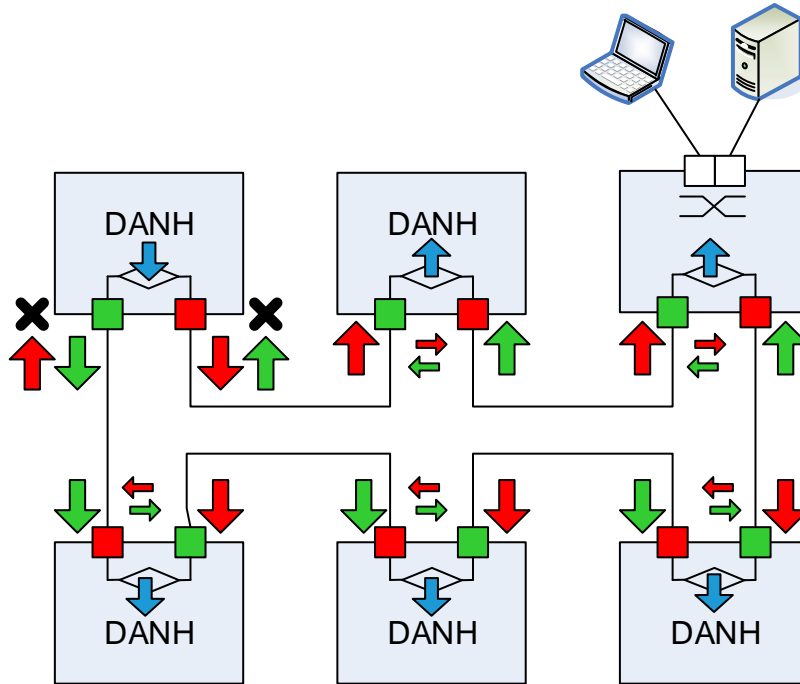

**Figure 2. HSR Ring Example with Multicast Message**

RedBox is a device that connects non-HSR nodes to the ring. The end-nodes that connect directly to the ring are also called Double Attached Node implementing HSR (DANH).

A frame in a ring is HSR tagged (Figure 3). HSR tags are added / removed by the nodes connected to the ring and ring exterior (RedBox). Source nodes send always two copies (red and green arrows) of the original frame (blue arrow) to the ring. The intermediate nodes forward frames and the destination node discards the duplicate that arrives later. The duplicate frames are identified by having the same source MAC address and sequence number. In case a frame travels full ring (in unicast no destination found, in multicast always), the source node takes care of the removal of the frame from the ring (X-marking in Figure 2).

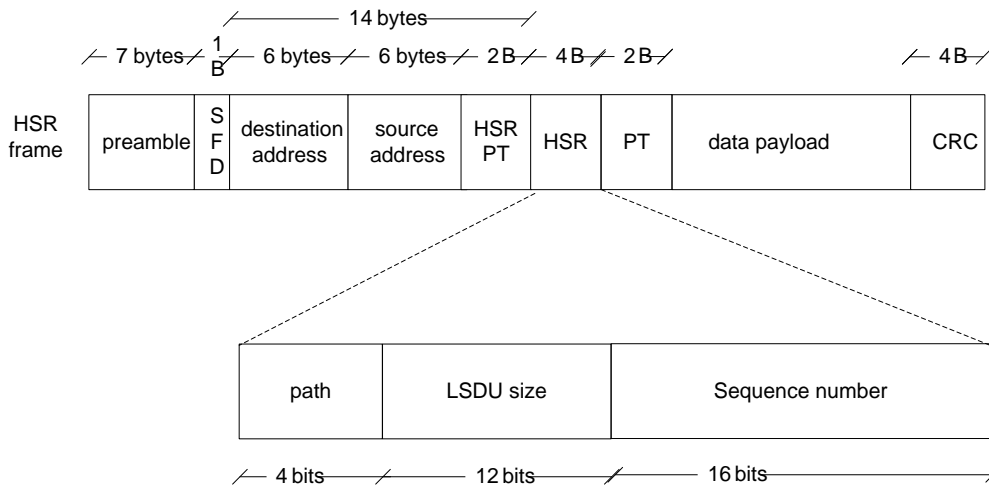

**Figure 3. HSR Tagged Frame**

HSR provides zero-loss redundancy – i.e. no frames are lost in case of single failure in the network. Applications do not see the underlying redundancy protocol because above link



layer everything works just as in normal Ethernet. Application does not detect a single failure in the network because it is able to receive all the frames normally. Occasionally however frames may go into wrong order in error situations, which applications have to be able to tolerate.

## 2.2 PRP

PRP [2] specifies a method to provide redundancy in Ethernet networks. The concept introduces double LAN networks, where source and destination are connected via two independent LANs (Local Area Networks). In a case where one of the LANs fails, PRP network still provides connection between source and destination(s) via second LAN, as shown in Figure 4. The standard has been developed for demanding and critical applications such as substation automation.

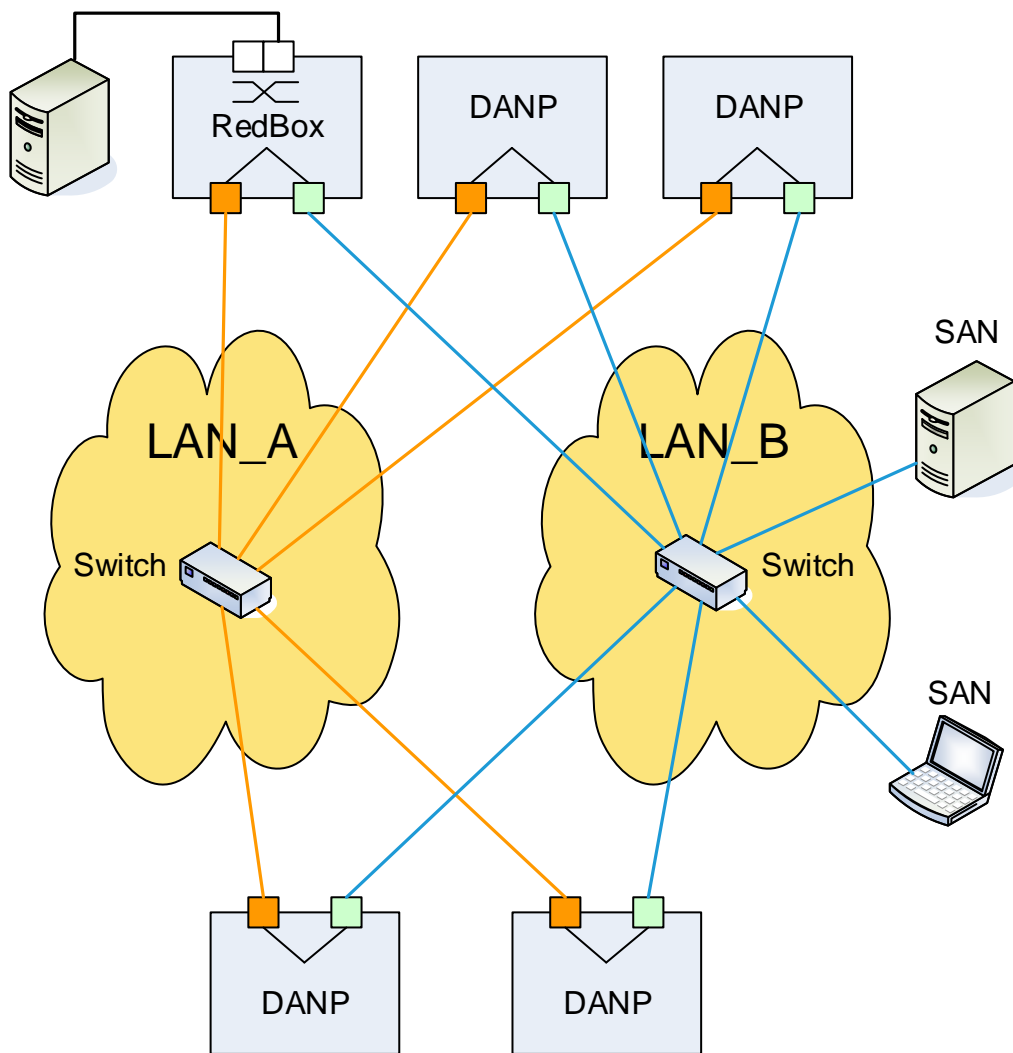

**Figure 4. PRP Network**

A PRP network example is depicted in Figure 4. All PRP capable nodes are connected via two separate networks, LAN\_A and LAN\_B, both constructed using normal non-PRP-aware Ethernet switches. All messages are sent to both networks and target device drops the duplicate frame that arrives later. In a PRP network, there can also be single attached nodes (SAN) that connect to only one of the LANs (LAN\_A or LAN\_B).

A RedBox is a device that connects non-PRP nodes to the redundant PRP network. The end-nodes that connect directly to both LANs are referred as Double Attached Node implementing PRP (DANP).

PRP frames have PRP trailers (see Figure 5). PRP trailer is added / removed by the PRP nodes (DANP) and ring exterior (RedBox). Source nodes send always two copies of the original frame, one for both LANs. The destination node discards the duplicate frame that arrives later. The duplicate frames are identified by having the same source MAC address and sequence number.

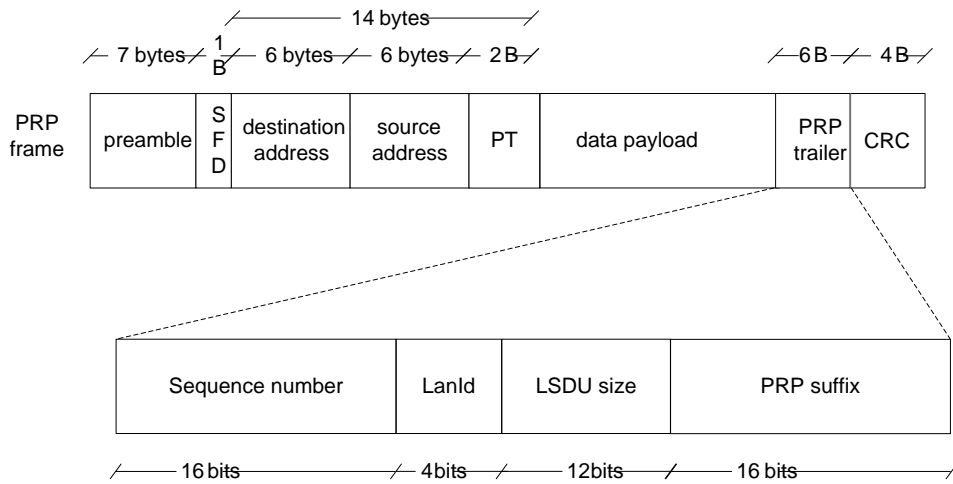

Figure 5. PRP Frame

PRP provides zero-loss redundancy which means that no frames are lost in case of a single failure in the network. Applications do not know anything about the underlying redundancy protocol because above link layer the network connection looks like normal Ethernet. The application does not see a single failure in the network as lost frames, but occasionally in failure situations frames may go into wrong order.

### 2.3 PTP

The Precision Time Protocol (PTP), defined in IEEE standard 1588 [1], enables precise synchronization of device clocks in packet based networks. Devices are automatically synchronized to the most accurate clock in the network. The protocol supports system wide synchronization accuracy, usually in the sub microsecond range, with minimal network and local clock computing resources. The protocol is used in applications such as test and measurement, power-line management, industrial automation and telecoms.

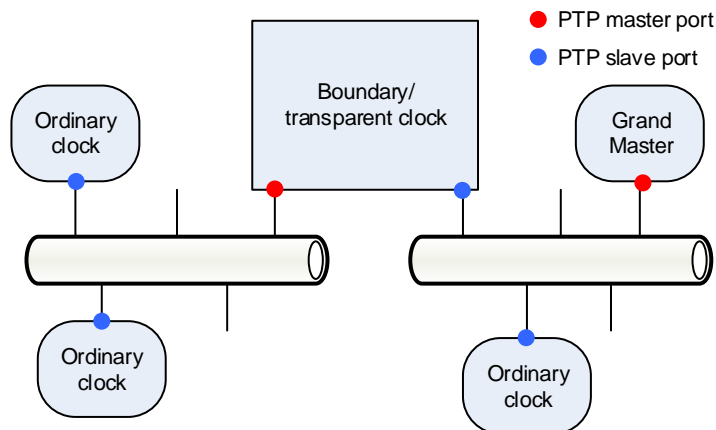
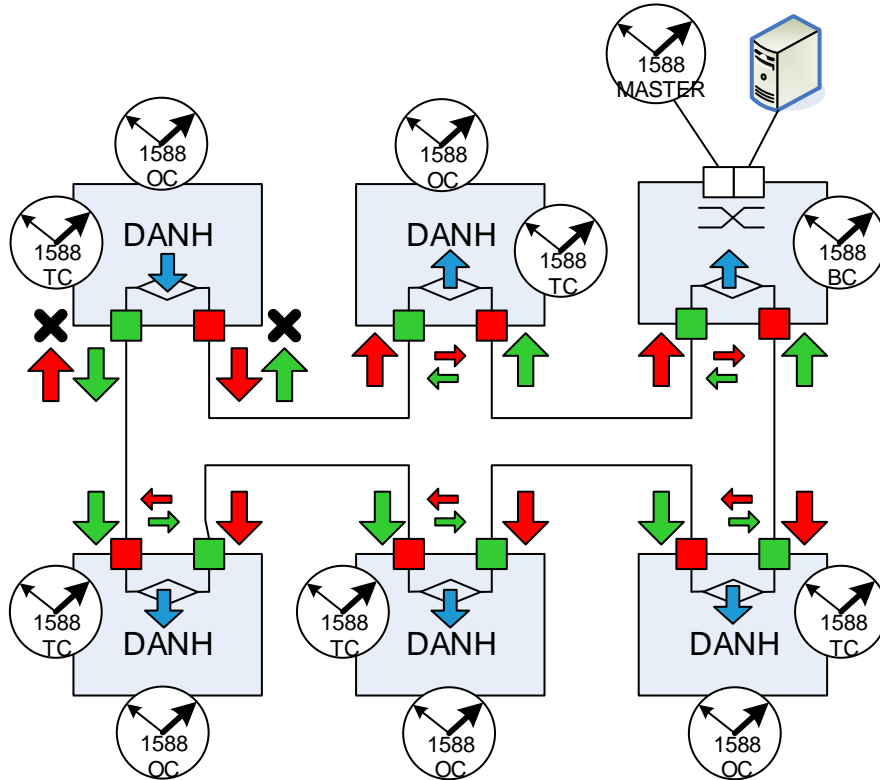

Figure 6. PTP Architecture

A PTP network is depicted in Figure 6. All the devices in the network are synchronized to a Grandmaster clock. Boundary clocks synchronize themselves and distribute synchronization to other network segments. Slave-only clocks (ordinary clock) only synchronize themselves. Transparent clocks forward synchronization information between network segments transparently.

PTP Power Profile [3] defines how PTP can be used in power system applications (see Figure 7).



**Figure 7. PTP Power Profile in HSR**

In HSR network (Figure 7) RedBox operates in BC (or TC) mode. Every DANH operates in TC mode between its ring ports and also as Slave Clock if the DANH needs the wall clock time for some purpose.

## 3 Test Network

### 3.1 General

The test network is presented in Figure 8. The network consists of twelve devices under test, forming two HSR rings and four PRP LANs altogether. The devices under test operate in a few different roles:

- PRP RedBox
- HSR RedBox
- HSR-HSR RedBox (half Quadbox)
- HSR-PRP RedBox
- PRP LAN center switch (normal Ethernet switch)

At the bottom in Figure 8 there are two PRP LANs (LAN\_A and LAN\_B), both of which have one central switch. One PRP RedBox (the lowest board in Figure 8) is connected to these PRP LANs. Both of these PRP LANs are connected to HSR Ring2 with a HSR-PRP RedBox. HSR Ring2 is then connected to HSR Ring1 with two QuadBoxes (both of the QuadBoxes consisting of two HSR-HSR RedBoxes). Then in the HSR Ring1 there are two HSR-PRP RedBoxes connecting the Ring1 to two PRP LANs (upper LAN\_A and LAN\_B). These PRP LANs do not have central switches. Instead they connect directly to the PRP RedBox at the top of Figure 8. This PRP RedBox connects to IEEE 1588 Grandmaster Clock which is the source for the time information in this network.

At Flexibilis the test network is built using FPGA evaluation boards, but other devices can also be used, depending on the purpose of the tests. All the devices need to implement IEEE 1588 PTP Transparent Clock (TC) between redundant ports. This is because Transparent Clock must be implemented in all the intermediate devices, or otherwise clock synchronization accuracy over the network will be drastically degraded. The devices under test can also include Ordinary Clocks, but that is not necessary for all the (intermediate) devices.

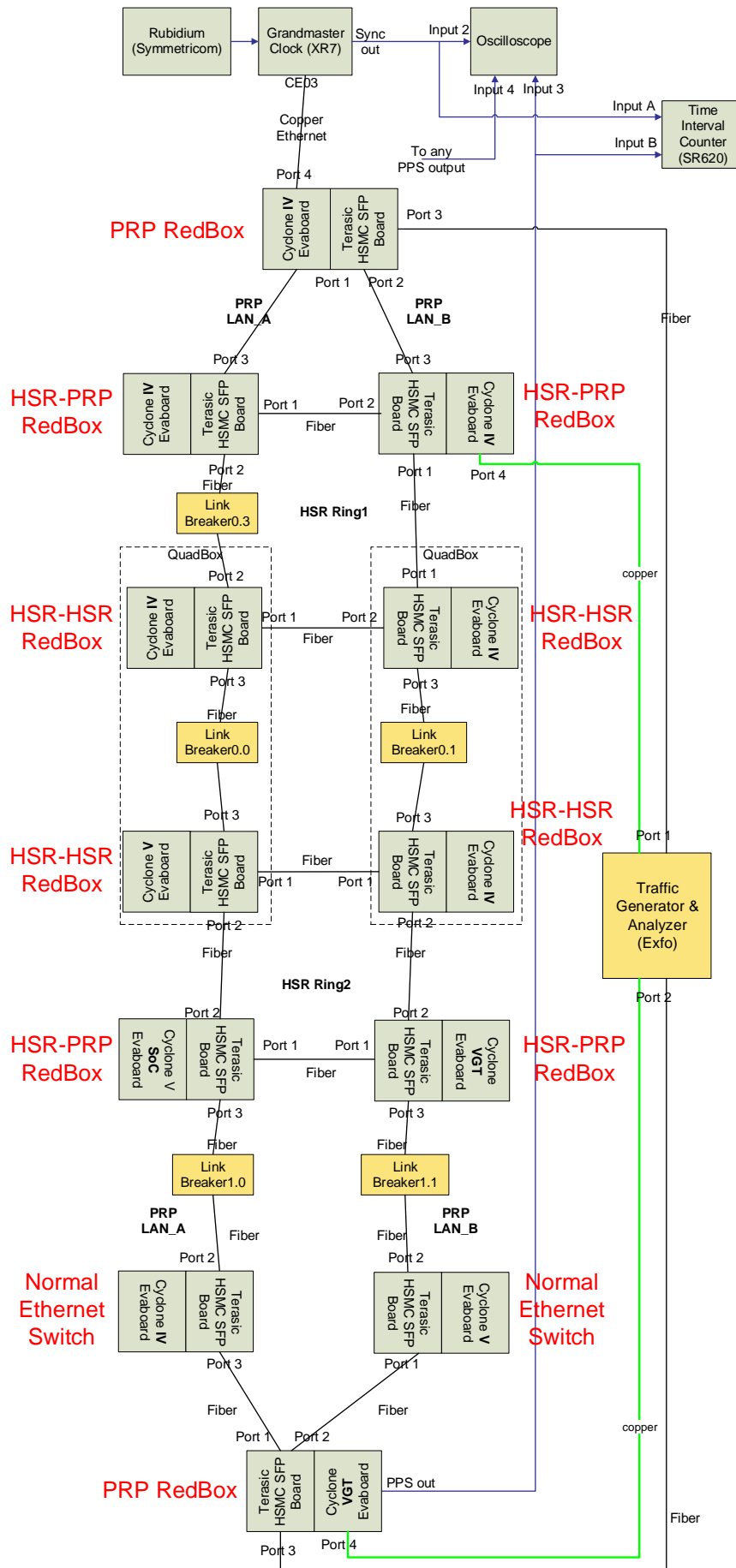

**Figure 8. Test Network**

In the test network at Flexibilis premises (Figure 8) the devices under test are constructed of FPGA development boards and SFP Extensions boards connected to them. SFP modules plugged into the SFP Extension boards provide Fiber optic links between the devices.

The traffic generator/analyzer transmits frames to the network and examines which ones of the frames can be received at the other end of the network and in which order. The grandmaster clock is the source of time information for the network, and the ordinary clocks in the network synchronize themselves to it. The oscilloscope and time interval counter are used to measure the time synchronization error at different network points.

In order to test redundancy and zero-loss property of HSR and PRP protocols, there has to be a way to produce failures into the network. This can be done by shutting off or resetting the network devices and by breaking and unbreaking network links (see LinkBreakers in Figure 8).

The Figure 8 network structure can be used to test other manufacturers' HSR/PRP devices too, as all the devices are normal HSR/PRP devices. In Figure 8 QuadBoxes are constructed using two HSR-HSR RedBoxes, who can be replaced with single-device QuadBoxes as well. Mixing devices from different manufacturers can be used in interoperability testing.

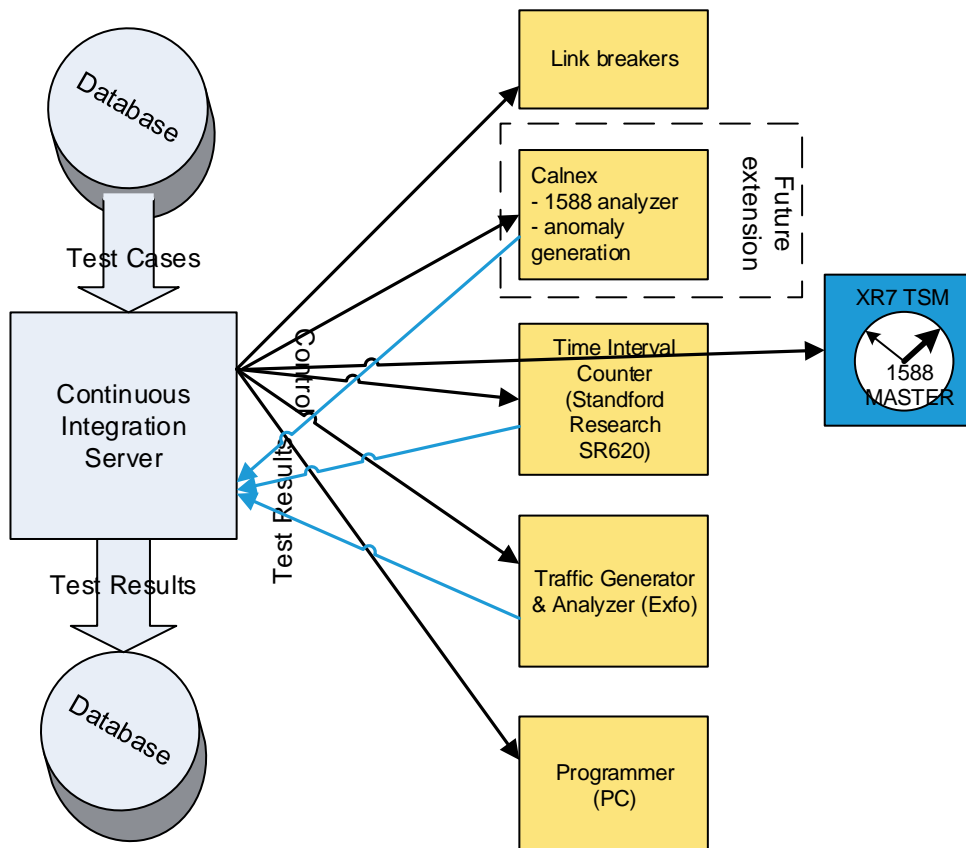

**Figure 9. Test Automation**

Figure 9 presents the system used for automating the execution of tests at Flexibilis. The Continuous Integration (CI) server reads test case execution instructions from a database and

controls the test devices accordingly. After each test has run it collects the test measurement data from the test devices, analyzes the test result and stores it to the database. This all happens automatically without human intervention. The system makes it possible to run tests outside work-hours, night-time and over weekends.

Testing in a network like this does not necessarily have to be automated, but for example manual link breaking by disconnecting and reconnecting the cable(s) during traffic tests can be very frustrating. In case of occasional compatibility tests this kind of manual steps are more acceptable than in tests that are repeated every day.

## 3.2 What to Test

The following subchapters list things that can be (should be) tested by different parties (switch IP provider, application provider, device manufacturer).

### 3.2.1 HSR/PRP Switch IP Provider

Implementing HSR (or PTP Power Profile) is not possible with pure software, which means that there is always an FPGA IP (or perhaps in the future an ASIC) doing the forwarding of the Ethernet frames, time stamping, etc. Testing the functionality of the IP is responsibility of the IP provider. An ethernet switch is quite a complex component and simulation times of Ethernet frames going through a switch are long, which means that the IP component has to be tested also at real hardware with real Ethernet traffic. Comprehensive testing of all the necessary HSR&PRP&PTP functionalities requires also having software that employs the IP functionality. This is the case especially with time synchronization functionality.

The Flexibilis implementation of an HSR/PRP switch IP is called FRS (Flexibilis Redundant Switch). Flexibilis has built a reference design around FRS that Flexibilis uses in its own tests in Figure 8 test network. The reference design is available for download at Flexibilis web site. Anybody is able to use these devices in their own test network setup:

<http://www.flexibilis.com/products/downloads/>

The test network makes it possible to test the IP core with huge amounts of Ethernet frames in a short time and the defects found in the test network can then be further tracked down in a simulation environment. Because of the long simulation times with traditional software-based simulators, Flexibilis uses a hardware accelerated simulator, Vertigo.

### 3.2.2 Application Provider

To upper layer protocols and applications the underlying HSR/PRP technology should be as invisible as possible. In normal operation this is true, but in error situations there is one exception: In HSR and PRP network the Ethernet frames can go into wrong order. Note that in IP network too frames can go in wrong order, so applications transferring data over IP have to tolerate frames being received in wrong order, but applications using Ethernet directly don't have to. For testing application behavior there are a few possibilities on how to emulate the situation of frames going into wrong order in Ethernet:

- Using a test device that can put Ethernet frames in the wrong order
- Writing an Ethernet driver that puts received (or sent) frames into wrong order
- Constructing an HSR or PRP network where one path between two devices is longer than the other path and disconnecting and reconnecting a network link at the shorter path

Otherwise the HSR/PRP network is a typical Ethernet network, which means that it cannot for example guarantee any kind of maximum delay. At least not without calculating and restricting the maximum amount of traffic sent any moment by every device in the network. Prioritizing application traffic over other traffic in the network helps in this because then the traffic amounts have to be calculated and restricted only for that priority level and those above. Most

applications still just ignore all this and just try to cope with certain amounts of delay and packet loss (audio and video applications for example buffer data because of this). But in certain mission-critical applications (substation automation for example) where maximum delay is important, total allowed network utilization levels must be calculated. From these calculations comes the maximum network delay the application must be able to tolerate.

### 3.2.3 Device Manufacturer

The device manufacturer is the one that integrates all the software and hardware pieces together and it has naturally very many things to test. The following lists things that can be tested in Figure 8 network.

#### HSR/PRP

- Maximum data throughput. Can the theoretical maximum throughput be reached? Note that the HSR header and PRP trailer cause some overhead which makes the theoretical throughput a little less than with traditional Ethernet. Note also that when traffic is sent in both directions at the same time, the throughput of HSR network drops to half because frames go around the whole ring consuming bandwidth of the other direction too. This is true also for unicast (not just for multicast) when there is more than one ring.
- Packet loss. There should be minimal or no packet loss. Note that Ethernet specification allows some packet loss too (BER < 10<sup>-12</sup> for 1000BASE-X).
- Packet delay. With low network utilization the measured maximum delay should be close to measured minimum delay.
- Prioritization. The experienced maximum delay with high network utilization should be significantly lower for higher priority frames than for lower priority frames.
- HSR/PRP supervision (if implemented) should be able to show information of all the nodes that implement HSR/PRP supervision.
- Replacing one device with another in a HSR ring should be possible during operation without causing frame loss to other devices or application layer conflicts. This simulates maintenance without maintenance break in the service.

#### IEEE 1588 PTP

- Synchronization accuracy. 1 us accuracy is required for example by Power Profile (over 16 hops). PPS outputs in the devices allow the synchronization accuracy to be easily measured (see Figure 8).
- Effect of other network traffic to synchronization accuracy. With prioritization network traffic with lower priority should affect accuracy only very little. Without prioritization the effect of other traffic is bigger, but devices should be able to synchronize themselves fine when adding more traffic up to the point where packet loss starts to be considerable.

#### Compatibility:

- Other manufacturers' devices
- Older devices of your own
- Co-operation with legacy technologies (RSTP, etc.)
- SAN connected to one PRP LAN only



### 3.3 Test Equipment

Table 1 and Table 2 list the equipment needed for building Figure 8 test network. Note that the automation degree of the test setup may be different which means that the devices in Table 2 may not be needed.

The network setup could include DANP and DANH devices too and they can be added to either one of the rings. Although from switch IP point of view for example DANH and RedBox is basically the same, just one port more in a RedBox (Put normal non-HSR Ethernet device in the same box with a RedBox and you'll have a DANH).

Equipment	Notes
Grandmaster Clock	Clock source for the HSR/PRP network.
2x PRP RedBox	Also HSR-HSR and HSR-PRP RedBoxes have normal HSR/PRP RedBox functionalities.
4x HSR-PRP RedBox	Connects a PRP LAN to HSR ring.
4x HSR-HSR RedBox	Half-QuadBoxes, can be replaced with two QuadBoxes
2x normal Ethernet switch	PRP LAN center switches
Ethernet Traffic Generator & Analyzer	Transmits frames and analyses received frames
Link Breakers	Remote controlled or manual. Used to cause link breaks (faults) to the network.
Oscilloscope	For manual viewing of synchronization accuracy

**Table 1. Test Equipment Needed**

Equipment	Notes
Continuous Integration (CI) server and test framework	For automated execution of tests
Clock source for grandmaster clock	GPS, Rubidium, Cesium, ...
Time Interval Counter	Automated measurement of clock synchronization accuracy

**Table 2. Optional Additional Test Equipment**

## 4 Test Cases

This chapter presents in details the test cases Flexibilis uses when testing FRS IP core in Figure 8 test network. There are separate paragraphs for traffic test that are made according to RFC 2544 and for other traffic tests. There are no separate tests for time synchronization using IEEE 1588 as time synchronization is tested during the traffic tests. The traffic tests test both HSR and PRP functionality and HSR/PRP compatibility at the same time as the test network has both HSR and PRP network segments.

### 4.1 RFC 2544 Traffic Tests

RFC 2544 defines a standard method for measuring the performance of networking devices. A standardized test method makes it easier to compare products of different manufacturers. The test can be used also during development. The RFC 2544 tests are best done using a third party test device to guarantee trustworthiness of the results. Flexibilis uses EXFO FTB-500 together with FTB-8510B Packet Blazer test module.

#### 4.1.1 Throughput Test

The RFC 2544 throughput test finds the maximum rate at which the tested network can transfer frames without losing a single one of them.

The test is made to one direction at a time, because in more complex HSR topologies than just one ring traffic in one direction consumes the same capacity in both directions. The tested combinations of interface type and frame size are presented in Table 3 and Table 4.

Interface type:	Interface Speed:
Copper	10 Mbit/s
	100 Mbit/s
	1000 Mbit/s
Fiber	1000 Mbit/s

**Table 3. Throughput Test Interface Types**

64 Bytes (Ethernet Minimum)
128
256
512
1024
1280
1518 Bytes (Ethernet Maximum)

**Table 4. Throughput Test Frame Sizes**

#### 4.1.1.1 Acceptance Criteria

When testing FRS the test result is accepted if the measured throughput is greater than or equal to values in Table 5.

Frame size	Throughput (% of physical line speed)
64	90
128	90
256	90
512	94
1024	97
1280	97
1518	98

**Table 5. Throughput Test Acceptance Criteria for FRS**

#### 4.1.2 Latency Test

The RFC 2544 latency test finds the latency of the test network as defined in RFC 1241.

The test is made to one direction at a time because in more complex HSR topologies than just one ring the traffic in one direction consumes the same capacity to both directions. The tested combinations of interface type and frame size are presented in Table 6 and Table 7.

The frame rate used in the test is 90% of the link nominal maximum capacity.

Interface type:	Interface Speed:
Copper	10 Mbit/s
	100 Mbit/s
	1000 Mbit/s
Fiber	1000 Mbit/s

**Table 6. Latency Test Interface Types**

64 Bytes (Ethernet Minimum)
128
256

512
1024
1280
1518 Bytes (Ethernet Maximum)

**Table 7. Latency Test Frame Sizes**

#### 4.1.2.1 Acceptance Criteria

When testing FRS the test result is accepted if the latencies are smaller or equal compared to values in Table 8. Number of hops in Figure 8 network is six.

Frame size	Max latency (µs), 10Mb	Max latency (µs), 100Mb	Max latency (µs), 1Gb
64	nr_hops * 400	nr_hops * 40	nr_hops * 35
128	nr_hops * 450	nr_hops * 45	nr_hops * 40
256	nr_hops * 550	nr_hops * 55	nr_hops * 40
512	nr_hops * 750	nr_hops * 75	nr_hops * 40
1024	nr_hops * 1200	nr_hops * 120	nr_hops * 42
1280	nr_hops * 1350	nr_hops * 135	nr_hops * 45
1518	nr_hops * 1600	nr_hops * 160	nr_hops * 50

**Table 8. Latency Test Acceptance Criteria for FRS**

#### 4.1.3 Frame Loss Test

The RFC 2544 Frame Loss test tests the frame loss in the network as defined in RFC 1241.

The RFC 2544 Frame Loss test finds the maximum rate at which the tested network can transfer frames without losing a single one of them. The test is done by starting with full rate and reducing the rate until all the frames go through. According to RFC 2544 the test is started at speed of 100% of the maximum rate, then at 90% rate and so on with 10% decrements until no frames are lost. Because of the overhead caused by the HSR header and PRP trailed we know that with 100% rate there will be frame loss. With 90% rate packet loss should not happen with FRS, so with FRS we can keep 0% packet loss at 90% rate as an acceptance criteria and not to test lower speeds at all. When testing other than FRS the test should be continued till no frame loss is seen.

The test is made to one direction at a time, because in more complex HSR topologies than just one ring traffic in one direction consumes the same capacity in both directions. The tested combinations of interface type and frame size are presented in Table 9 and Table 10.

<b>Interface type:</b>	<b>Interface Speed:</b>
------------------------	-------------------------

Copper	10 Mbit/s
	100 Mbit/s
	1000 Mbit/s
Fiber	1000 Mbit/s

**Table 9. Frame Loss Test Interface Types**

64 Bytes (Ethernet Minimum)
128
256
512
1024
1280
1518 Bytes (Ethernet Maximum)

**Table 10. Frame Loss Test Frame Sizes**

#### 4.1.3.1 Acceptance Criteria

When testing FRS the test result is accepted if the frame loss is smaller or equal compared to values in Table 11.

Frame Size (Bytes)      Link Usage (% of physical line speed)      Frame-loss (%)

Frame Size (Bytes)	Link Usage (% of physical line speed)	Frame-loss (%)
64	100	10
128	100	3
256	100	2
512	100	1
1024	100	1
1280	100	1
1518	100	1
64	90	0

128	90	0
256	90	0
512	90	0
1024	90	0
1280	90	0
1518	90	0

**Table 11. Frame Loss Test Acceptance Criteria for FRS**

### 4.2 Stream Sweep Tests

Stream Sweep tests are Flexibilis proprietary tests not following any RFCs or other standards. Instead, these tests have been specially designed to test functionality of HSR and PRP network, especially under network failure events. During the tests the network links are broken one at a time, which according to HSR and PRP specification should cause no frame loss. In addition to lost frames, the tests also measure number of frames that went to wrong order. Frames going to wrong order is allowed with HSR and PRP when link breaks occur, but not in fully functional network. Stream sweep tests are made with both unicast and multicast traffic and the IEEE 1588 PTP synchronization accuracy is monitored the whole time during the tests.

The tests are made to both directions at the same time, with link breaking and without link breaking, for all the combinations of interface types and frame sizes in Table 12 and Table 13.

Interface type:	Interface Speed:
Copper	10 Mbit/s
	100 Mbit/s
	1000 Mbit/s
Fiber	1000 Mbit/s

**Table 12. Stream Sweep Test Interface Types**

Frame size:	Number of different frame sizes tested:
56 Bytes to 63 Bytes (Undersize)	8
64 Bytes (Ethernet Minimum)	1
65 Bytes to 72 Bytes	8
92 Bytes to 108 Bytes	17

120 Bytes to 136 Bytes	17
248 Bytes to 264 Bytes	17
504 Bytes to 520 Bytes	17
1016 Bytes to 1032 Bytes	17
1272 Bytes to 1288 Bytes	17
1510 Bytes to 1517 Bytes	8
1518 Bytes (Ethernet Maximum without VLAN tag)	1
1519 Bytes to 1526 Bytes (Over Ethernet Maximum, but still forwarded by FRS)	8

**Table 13. Stream Sweep Test Frame Sizes**

This results in 136 (different frame sizes) \* 2 (link breaking sequence on/off) \* 2 (unicast/broadcast) \* 4 (speed&linktype combinations) = 2176 separate test runs. The frame rate used in each test run is a 10-step ramp from 0 up to 45% of the link nominal maximum capacity (45% of non-HSR link capacity is quite close to HSR maximum capacity). Each step of the ramp lasts for one second which corresponds to 10 second total runtime (see Figure 10). 2176 test runs \* 10 seconds/test run = about 6 hours total effective test time for all the stream sweep tests. With the current Flexibilis test setup the time taken by reconfiguring of the test devices doubles the total test time to 12 hours.

When testing time limited versions of FRS, the boards running FRS are reset after certain amount of test runs. If there is no time limit, the tests are run one after another without resetting the devices. In case of reset, IEEE 1588 PTP is allowed to synchronize for 60 seconds before the next test is started.

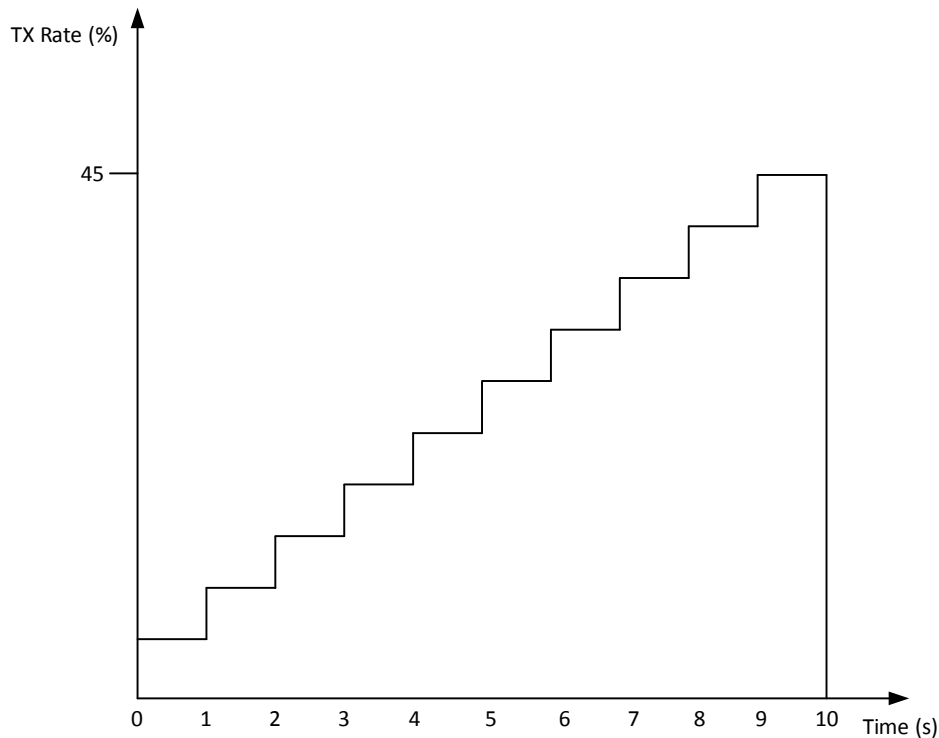

**Figure 10. Transmit Rate Ramp up**

Because of the big total length of the tests (about 3h per media type & link speed combination) there are also shorter versions of the tests, for trying out new versions (of the IP core) more quickly.

#### 4.2.1 Link Breaking Sequence

The HSR/PRP specification promises zero loss recovery in case of a single fault in the network. In order to test this functionality, there are a few link breaker in the test network (LinkBreaker0.0, LinkBreaker0.1, LinkBreaker0.3, LinkBreaker 1.0 and LinkBreaker1.1 in Figure 8.)

The link breaking sequence is the following:

1. Connect all the links
2. Wait for four seconds
3. Pseudorandomly select one LinkBreaker and break the link
4. Wait for one second
5. Goto 1.

#### 4.2.2 Acceptance Criteria

The test result is accepted if all of the below is true:

- Frames whose length is under 64 bytes do not go through
- All the frames whose length is greater than or equal to 64 bytes transmitted from Traffic Generator/Analyzer port 1 are received at Traffic Generator/Analyzer port 2
- All the frames whose length is greater than or equal to 64 bytes transmitted from Traffic Generator/Analyzer port 2 are received at Traffic Generator/Analyzer port 1
- There are no duplicate frames received at the Traffic Generator/Analyzer
- When the link breaking sequence is not enabled, frames are received in the the same order they were sent.



- The time difference between the Grandmaster and the device most far away from it is not more than 0.5 microseconds any time during the test.

The above acceptance criteria is used for testing FRS at Flexibilis, but these are valid requirements for other HSR/PRP devices as well.

## 5 Abbreviations

<b>Term</b>	<b>Description</b>
AFEC	Advanced Flexibilis Ethernet Controller
DANH	Double attached node implementing HSR
DANP	Double attached node implementing PRP
FRS	Flexibilis Redundant Switch
FRTC	Flexibilis Real-Time Clock
HSR	High-availability Seamless Redundancy
PRP	Parallel Redundancy Protocol
PTP	Precision Time Protocol
SAN	Singly Attached Node

## 6 References

- [1] IEEE Standard for a Precision Clock Synchronization Protocol for Networked Measurement and Control Systems, IEEE Std 1588™-2008
- [2] High-availability Seamless Redundancy (HSR), IEC 62439-3:2011
- [3] IEEE Standard Profile for Use of IEEE 1588™ Precision Time Protocol in Power System Applications, IEEE Std 37.238™-2011
- [4] Benchmarking Methodology for Network Interconnect Devices, IETF RFC2544, <http://www.ietf.org/rfc/rfc2544>